



Model RHS32

How to install, operate and maintain your Demand Controlled Water Softener

PRODUCT REGISTRATION AND WARRANTY EXTENSION

Please register your product on rheemwatertreatment.com

See warranty page for extended warranty details.



If you have any questions or concerns when installing, operating or maintaining your water softener, call our toll free number:

1-800-754-7027

or visit www.rheemwatertreatment.com

When you call, please be prepared to provide the model and serial number of your product, found on the rating decal inside the salt lid.



System tested and certified by NSF International against NSF/ANSI Standard 44 for hardness reduction, efficiency and the reduction of barium and radium 226/228, and certified to NSF/ANSI/CAN Standard 372.



System tested and certified by the Water Quality Association against CSA B483.1.



C US

Manufactured and warranted by
Water Channel Partners
2805 Dodd Road, Suite 300
Eagan, MN 55121

7386465 (Rev. M 2/6/25)

Installation and Operation Manual

TABLE OF CONTENTS

| | Page |
|---|-------|
| Specifications & Performance Claims | 3 |
| Before You Start | 4 |
| Inspect Shipment | 5 |
| Water Conditioning Information | 5 |
| Installation Requirements | 6-7 |
| Installation Instructions | 8-11 |
| Programming the Water Softener | 12-14 |
| Customizing Features | 15-16 |
| Routine Maintenance | 17-18 |
| Troubleshooting | 19-21 |
| Exploded View & Parts List | 22-25 |
| Warranty | 26 |

Dimensions

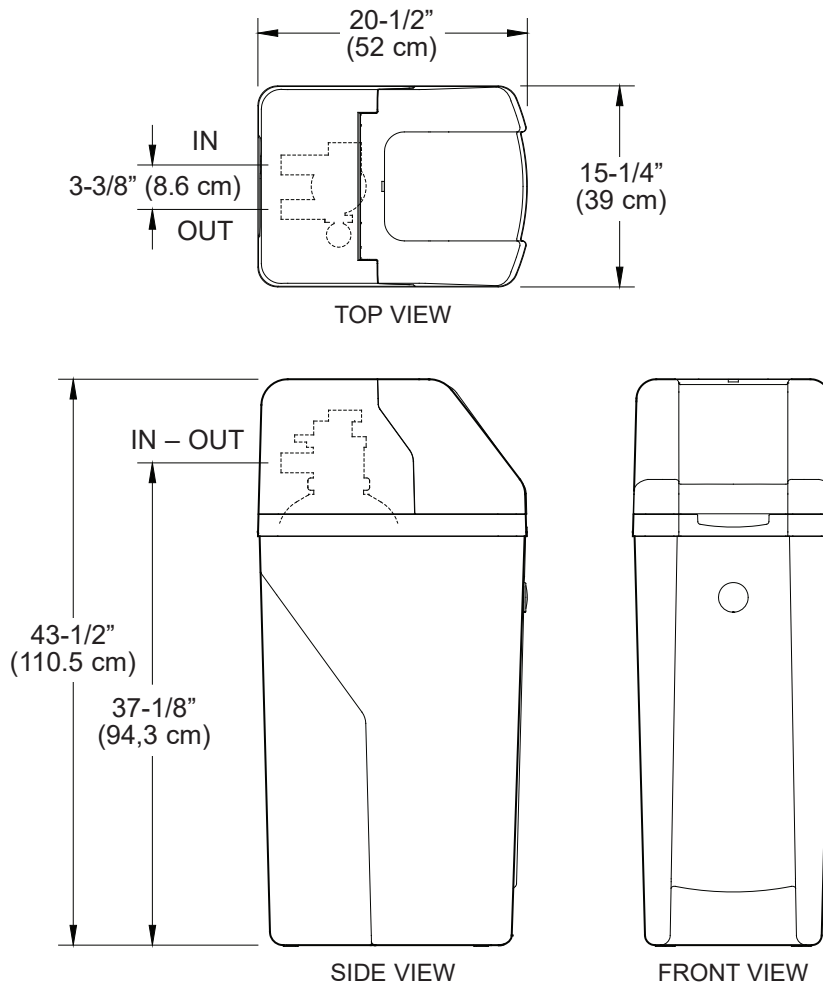

FIG. 1

Specifications & Performance Claims

This model is efficiency rated. The efficiency rating is valid only at the minimum salt dose. This system has a demand initiated regeneration (D.I.R.) feature that complies with specific performance specifications intended to minimize the amount of regenerant brine and water used in their operation.

This water softener has a rated softener efficiency of not less than 3,350 grains of total hardness exchange per pound of salt (based on sodium chloride) and shall not deliver more salt than its listed rating or be operated at a sustained maximum service flow rate greater than its listed rating. This system has been proven to deliver soft water for at least ten continuous minutes at the rated service flow rate. The rated salt efficiency is measured by laboratory tests described in NSF/ANSI Standard 44. These tests represent the maximum possible efficiency that the system can achieve. Operational efficiency is the actual efficiency after the system has been installed. It is typically less than the rated efficiency, due to individual application factors including water hardness, water usage, and other contaminants that reduce a softener's capacity.

| | Model RHS32 |
|---|--|
| Model Code | rH32 |
| Rated Softening Capacity (Grains @ Salt Dose) | 13,000 @ 2.6 lbs. 27,600 @ 8.3 lbs. 33,000 @ 14.1 lbs. |
| Rated Efficiency (Grains/Pound of Salt @ Minimum Salt Dose) | 4,940 @ 2.6 lbs. |
| Water Used During Regeneration @ Minimum Salt Dose | 1.9 gallons (7.2 L) / 1,000 grains |
| Total Water Used Per Regeneration @ Maximum Salt Dose | 33.3 gallons (126.1 L) |
| Rated Service Flow Rate | 7.9 gpm (29.9 lpm) |
| Amount of High Capacity Ion Exchange Resin | 0.88 cu. ft. |
| Pressure Drop at Rated Service Flow | 14.9 psig |
| Intermittent Flow Rate @ 30 psi | 11.8 gpm (44.7 lpm)* |
| Water Supply Max. Hardness | 105 gpg |
| Water Supply Max. Clear Water Iron | 8 ppm** |
| Water Pressure Limits (min. / max.) | 20 - 125 PSI (138 - 862 kPa)*** |
| Water and Ambient Temperature Limits (min. / max.) | 40 - 120 °F (5 - 49 °C) |
| Minimum Water Supply Flow Rate | 3 gpm (11.4 lpm) |
| Maximum Drain Flow Rate | 2.0 gpm (7.6 lpm) |

*Intermittent flow rate does not represent the maximum service flow rate used for determining the softener's rated capacity and efficiency. Continuous operation at flow rates greater than the service flow rate may affect capacity and efficiency performance.

**Capacity to reduce clear water iron is substantiated by laboratory test data. State of Wisconsin requires additional treatment if water supply contains clear water iron exceeding 5 ppm.

***Canada working pressure limits: 1.4 - 7.0 kg/cm².

This system conforms to NSF/ANSI Standard 44 for the specific performance claims as verified and substantiated by test data.

Variable Salt Dose: The salt dose is selected by the electronic controls at regeneration time based on the amount needed.

| PERFORMANCE CLAIMS | | |
|---------------------------|---------------------------------|--|
| Contaminant | Influent Challenge Level | Maximum Allowable Product Water Level |
| Barium | 10 ±10% mg/L | 2.0 mg/L |
| Radium 226/228 | 25 pCi/L | 5 pCi/L |

Questions? Call Toll Free 1-800-754-7027 or visit **www.rheemwatertreatment.com**

When you call, please be prepared to provide the model and serial number, found on the rating decal inside the salt lid.

Before You Start

- The water softener requires a minimum water flow of 3 gallons per minute at the inlet. Maximum allowable inlet water pressure is 125 psi. If daytime pressure is over 80 psi, nighttime pressure may exceed the maximum. Use a pressure reducing valve if necessary (Adding a pressure reducing valve may reduce the flow). If your home is equipped with a back flow preventer, an expansion tank must be installed in accordance with local codes and laws.
- The water softener works on 24V DC electrical power, supplied by a direct plug-in power supply (included). Be sure to use the included power supply and plug it into a nominal 120V, 60 Hz household outlet that is in a dry location only, grounded and properly protected by an overcurrent device such as a circuit breaker or fuse.
- Do not use this system to treat water that is microbiologically unsafe or of unknown quality without adequate disinfection upstream or downstream of the system.
- If the system is being used to reduce barium and/or radium 226 and 228, please verify softener performance annually by having your treated water supply tested for water hardness at a local water testing laboratory, or by contacting Legend Technical Services, an independent laboratory, at 1-800-949-8220.



European Directive 2002/96/EC requires all electrical and electronic equipment to be disposed of according to Waste Electrical and Electronic Equipment (WEEE) requirements. This directive or similar laws are in place nationally and can vary from region to region. Please refer to your state and local laws for proper disposal of this equipment.

In the state of Massachusetts: The Commonwealth of Massachusetts plumbing code 248-CMR shall be adhered to. A licensed plumber shall be used for this installation.

In the state of California: You must turn the Salt Efficiency Feature setting to ON. This may initiate more frequent recharges. However, it will operate at 4,000 grains per pound of salt or higher. To turn on the Salt Efficiency Feature, follow the instructions in the "Salt Efficiency" section of this manual.

Do not return the water softener to store.

If you have any questions, or there are missing parts or damage, please call **Toll Free 1-800-754-7027** or visit **www.rheemwatertreatment.com**

When you call, please be prepared to provide the model and serial number, found on the rating decal inside the salt lid.

Inspect Shipment

The parts required to assemble and install the water softener are included with the unit. Thoroughly check the water softener for possible shipping damage and parts loss. Also, inspect and note any damage to the shipping carton.

Remove and discard (or recycle) all packing materials. To avoid the loss of small parts, we suggest you keep the small parts in the parts bag until you are ready to use them.

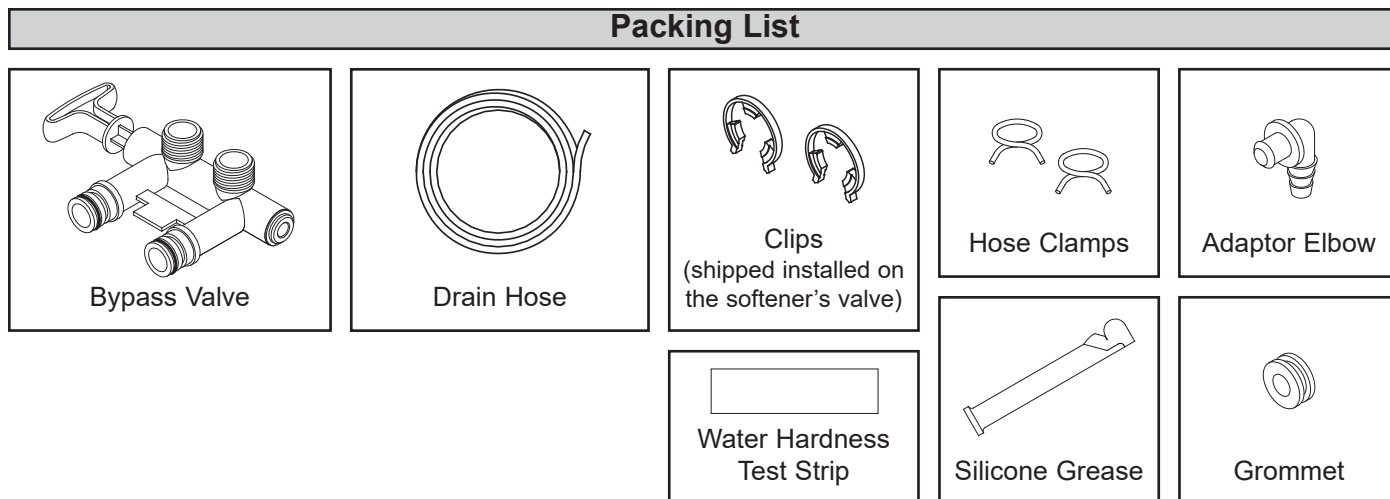

FIG. 2

Water Conditioning Information

IRON

Iron in water can cause stains on clothing and plumbing fixtures. It can negatively affect the taste of food, drinking water, and other beverages. Iron in water is measured in parts per million (ppm). The total* ppm of iron, and type or types*, is determined by chemical analysis. Four different types of iron in water are:

- Ferrous (clear water) iron
- Ferric (red water) iron
- Bacterial and organically bound iron
- Colloidal and inorganically bound iron (ferrous or ferric)

Ferrous (clear water) iron is soluble and dissolves in water. This water softener will reduce moderate amounts of this type of iron (see specifications).**

Ferrous (clear water) iron is usually detected by taking a sample of water in a clear bottle or glass.

Immediately after taking, the sample is clear. As the water sample stands, it gradually clouds and turns slightly yellow or brown as air oxidizes the iron. This usually occurs in 15 to 30 minutes.

When using the softener to reduce Ferrous (clear water) iron, add 5 grains to the hardness setting for every 1 ppm of Ferrous (clear water) iron. See "Set Water Hardness Number" section.

Ferric (red water), and bacterial and organically bound irons are insoluble. This water softener will not remove

ferric or bacterial iron. This iron is visible immediately when drawn from a faucet because it has oxidized before reaching the home. It appears as small cloudy yellow, orange, or reddish suspended particles. After the water stands for a period of time, the particles settle to the bottom of the container. Generally, these irons are removed from water by filtration. Chlorination is also recommended for bacterial iron.

Colloidal and inorganically bound iron is of ferric or ferrous form that will not filter or exchange out of water. This water softener will not remove colloidal iron. In some instances, treatment may improve colloidal iron water. Colloidal iron water usually has a yellow appearance when drawn. After standing for several hours, the color persists and the iron does not settle, but remains suspended in the water.

SEDIMENT

Sediment is fine, foreign material particles suspended in water. This water softener will not remove sediment. This material is most often clay or silt. Extreme amounts of sediment may give the water a cloudy appearance. A sediment filter installed upstream of the water softener normally corrects this situation.

* Water may contain one or more of the four types of iron and any combination of these. Total iron is the sum of the contents.

** Capacity to reduce clear water iron is substantiated by laboratory test data.

Installation Requirements

LOCATION REQUIREMENTS

Consider all of the following when selecting an installation location for the water softener.

- Do not locate the water softener where freezing temperatures occur. Do not attempt to treat water over 120°F. Freezing temperatures or hot water damage voids the warranty.
- To condition all water in the home, install the water softener close to the water supply inlet, and upstream of all other plumbing connections, except outside water pipes. Outside faucets should remain on hard water to avoid wasting conditioned water and salt.
- A nearby drain is needed to carry away regeneration discharge (drain) water. Use a floor drain, laundry tub, sump, standpipe, or other options (check your local codes). See "Air Gap Requirements" and "Valve Drain Requirements" sections.
- The water softener works on 24V DC electrical power, supplied by a direct plug-in power supply (included). Provide nearby a 120V, 60 Hz electrical outlet in accordance with NEC and local codes.
- Always install the water softener between the water inlet and water heater. Any other installed water conditioning equipment should be installed between the water inlet and water softener (See Figure 4 below).
- Avoid installing in direct sunlight. Excessive sun heat may cause distortion or other damage to non-metallic parts.
- Install on a flat, stable surface that evenly supports the weight of the water softener.

PLUMBING CODES

All plumbing must be completed in accordance with national, state and local plumbing codes.

In the state of Massachusetts: The Commonwealth of Massachusetts plumbing code 248-CMR shall be adhered to. A licensed plumber shall be used for this installation.

AIR GAP REQUIREMENTS

A drain is needed for the water discharged from the valve during the softener's regeneration cycle (See Figure 3). A floor drain, close to the water softener, is preferred. A laundry tub, standpipe, etc. are other drain options. Secure valve drain hose in place. Leave an air gap of 1-1/2" between the end of the hose and the drain. This gap is needed to prevent backflow of sewer water into the water softener. Do not put the end of the drain hose into the drain.

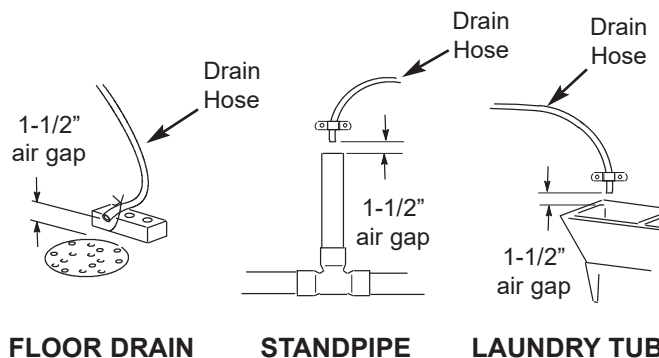

FIG. 3

THE PROPER ORDER TO INSTALL WATER TREATMENT EQUIPMENT

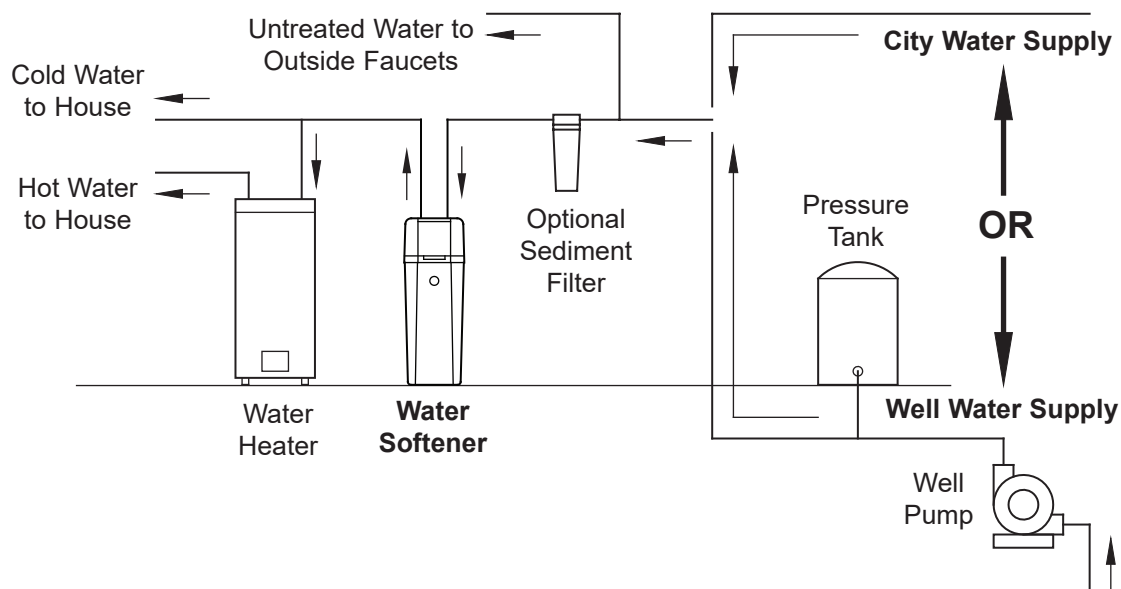

FIG. 4

Installation Requirements

VALVE DRAIN REQUIREMENTS

Using the flexible drain hose (included), measure and cut to the length needed. Flexible drain hose is not allowed in all localities (check your plumbing codes). If local codes do not allow use of a flexible drain hose, a rigid valve drain run must be used. Purchase a compression fitting (1/4 NPT x 1/2 in. minimum tube) and 1/2" tubing from your local hardware store. Plumb a rigid drain as needed (See Figure 6).

NOTE: Avoid drain hose runs longer than 30 feet. Avoid elevating the hose more than 8 feet above the floor. Make the valve drain line as short and direct as possible.

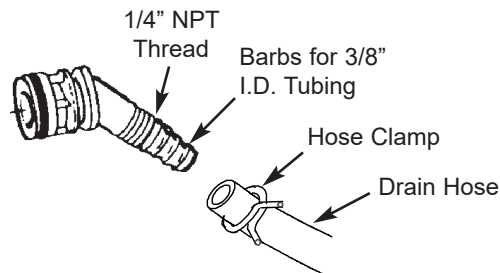

FIG. 5

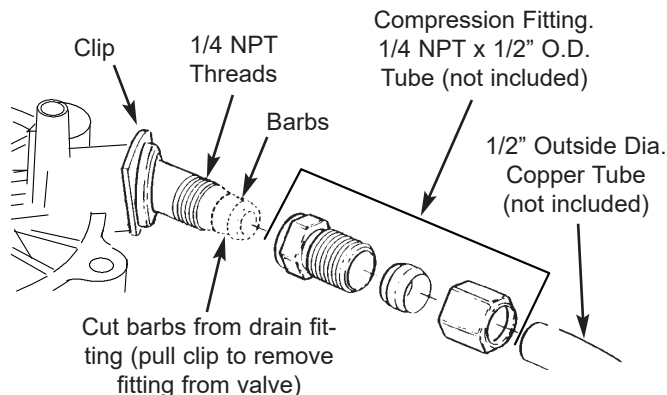

FIG. 6

INLET / OUTLET PLUMBING OPTIONS

Always install either a single bypass valve (provided), as shown in Figure 7, or, if desired, parts for a 3 valve bypass system (not included) can be purchased and assembled, as shown in Figure 8. Bypass valves allow you to turn off water to the softener for maintenance if needed, but still have water in house pipes.

Use:

- Copper pipe
- Threaded pipe
- PEX (Crosslinked Polyethylene) pipe
- CPVC plastic pipe
- Other pipe approved for use with potable water

IMPORTANT: Do not solder with plumbing attached to the single bypass valve. Soldering heat will damage the plastic valve.

SINGLE BYPASS VALVE

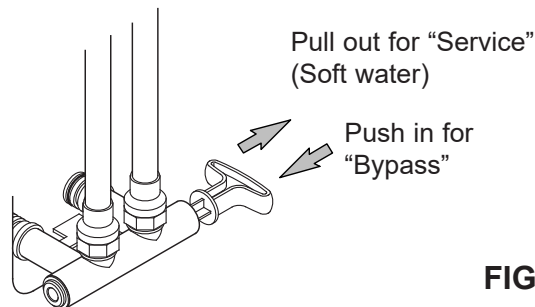

FIG. 7

3 VALVE BYPASS

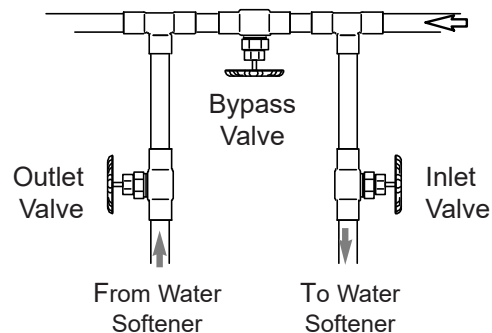

FIG. 8

Installation Instructions

TYPICAL INSTALLATION

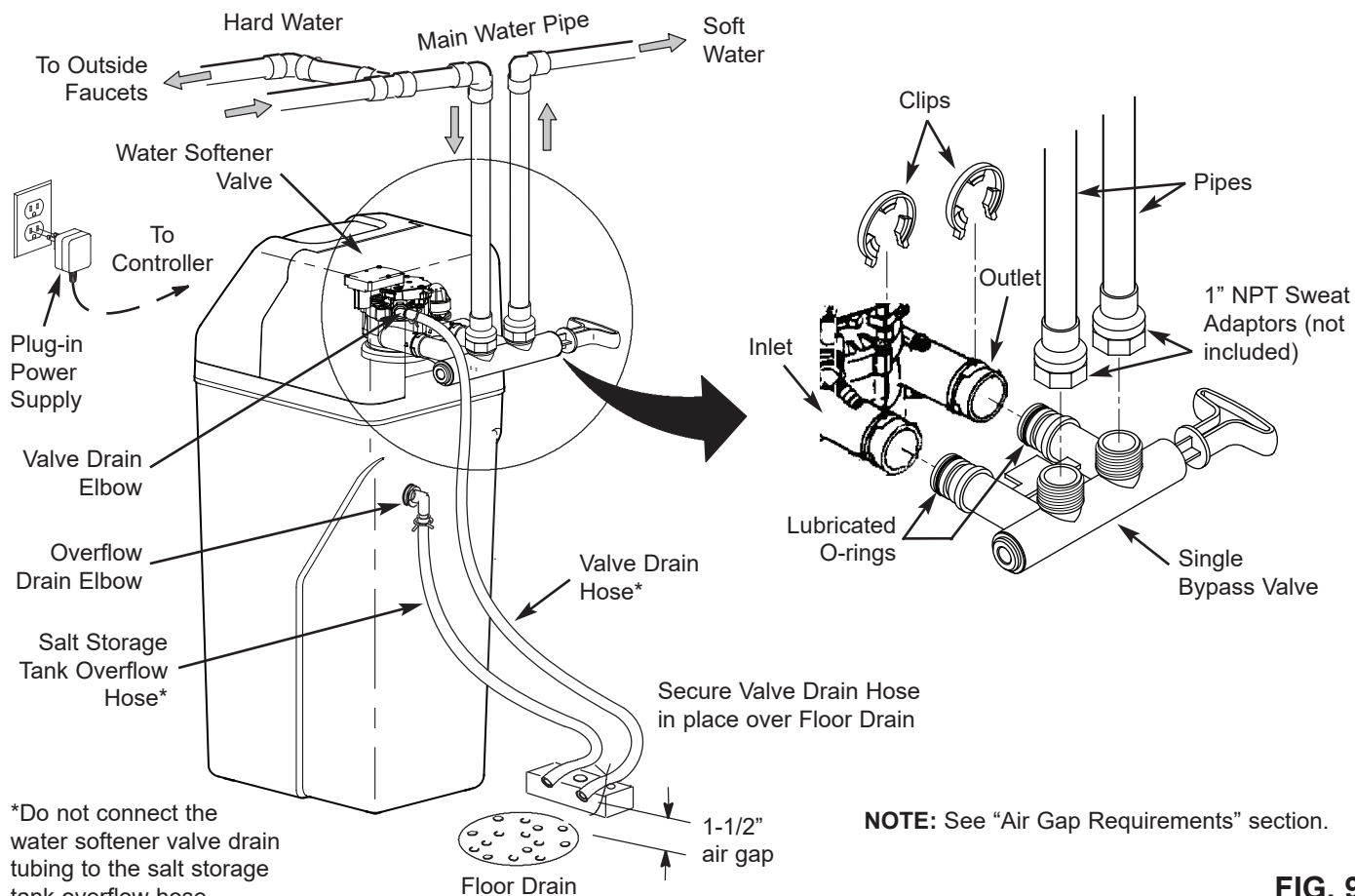

FIG. 9

TURN OFF WATER SUPPLY

1. Close the main water supply valve, located near the well pump or water meter.
2. Shut off the electric or fuel supply to the water heater.
3. Open all faucets to drain all water from house pipes.

NOTE: Be sure not to drain water from the water heater, as damage to the water heater elements could result.

ASSEMBLY

1. Rheem® models are factory assembled. During installation, unsnap and remove the top cover, together with the salt lid, to expose the softener valve assembly. Set them aside to prevent damage. Check the brinewell to be sure it is secured and vertical (See Figure 11).
2. Install the brine tank overflow grommet and elbow into the 13/16" diameter hole in the back of the salt storage tank wall.

MOVE THE UNIT INTO PLACE

1. Move the water softener into the desired location. Set it on a solid, level surface.

IMPORTANT: Do not place shims directly under the salt storage tank to level the softener. The weight of the tank, when full of water and salt, may cause the tank to fracture at the shim.

2. Visually check and remove any debris from the water softener valve inlet and outlet ports. Carefully remove the two large plastic clips (you will use them).
3. Make sure the turbine assembly spins freely in the "out" port of the valve (See Figure 10).
4. If not already done, put a light coating of silicone grease on the single bypass valve o-rings.
5. Push the single bypass valve into the softener valve as far as it will go. Snap the two large holding clips into place, from the top down as shown in Figures 12 & 13.

IMPORTANT: Be sure the clips snap firmly into place so the single bypass valve will not pull out.

Installation Instructions

COMPLETE INLET AND OUTLET PLUMBING

Measure, cut, and loosely assemble pipe and fittings from the main water pipe to the inlet and outlet ports of the water softener valve. Be sure to keep fittings fully together, and pipes squared and straight.

Be sure hard water supply pipe goes to the water softener valve inlet side.

NOTE: Inlet and outlet are marked on the water softener valve. Trace the water flow direction to be sure hard water is to inlet.

IMPORTANT: Be sure to fit, align and support all plumbing to prevent putting stress on the water softener valve inlet and outlet. Undue stress from misaligned or unsupported plumbing may cause damage to the valve.

Complete the inlet and outlet plumbing for the type of pipes you will be using.

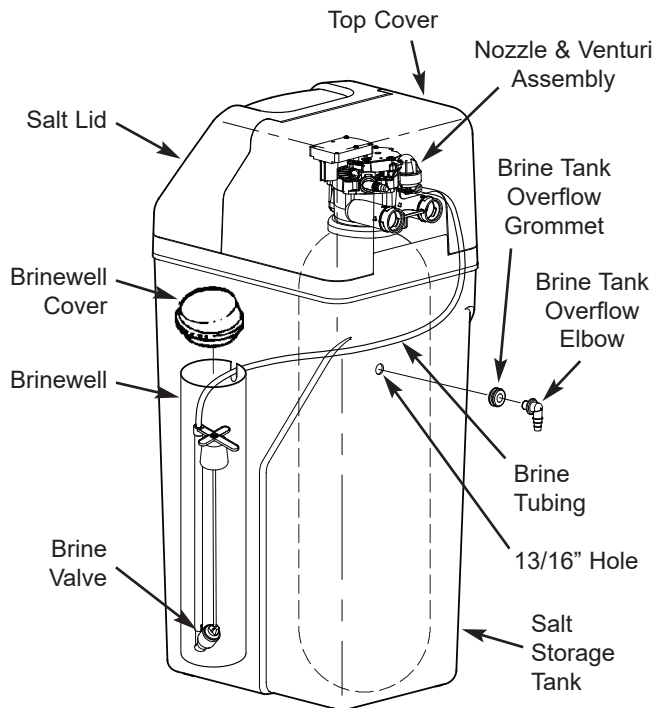

FIG. 11

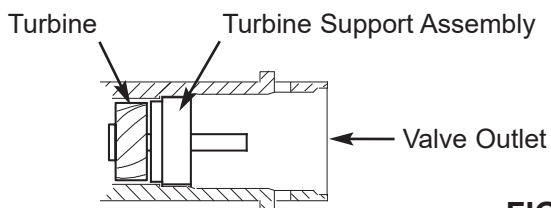

FIG. 10

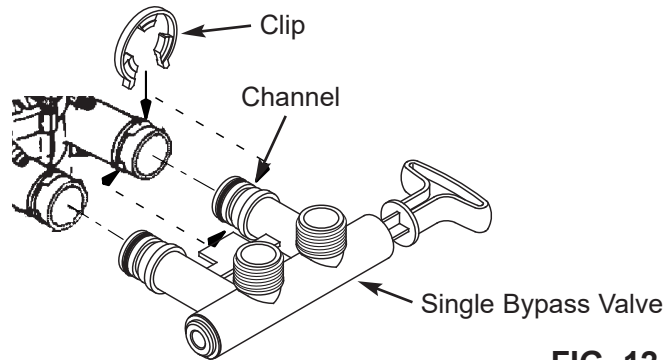

FIG. 12

Correct Assembly

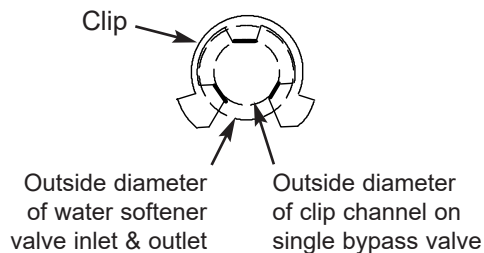

FIG. 13

NOTE: Be sure all 3 tabs of the clip go through the matching holes on the water softener valve inlet or outlet, and fully into the channel on the single bypass valve. Make sure that the tabs are fully seated.

Installation Instructions

COLD WATER PIPE GROUNDING

CAUTION: The house cold water pipe (metal only) is often used as a ground for the house electrical system. The 3-valve bypass type of installation, shown in Figure 8, will maintain ground continuity. If you use a plastic bypass valve at the unit, continuity is broken. To restore the ground, do the following:

1. Install a #4 copper wire across the removed section of main water pipe, securely clamping it at both ends (See Figure 14) - parts not included.

NOTE: Check local plumbing and electrical codes for proper installation of the ground wire. The installation must conform to them. In Massachusetts, plumbing codes of Massachusetts shall be conformed to. Consult with your licensed plumber.

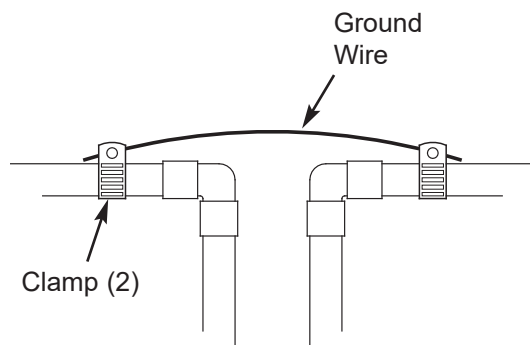

FIG. 14

INSTALL VALVE DRAIN HOSE

NOTE: See valve drain options on pages 6 & 7.

1. Measure, cut to needed length and connect the 3/8" drain line (provided) to the water softener valve drain fitting. Use a hose clamp to hold the hose in place.

IMPORTANT: If codes require a rigid drain line see "Valve Drain requirements" section.

2. Run the drain hose (or a rigid line) to the floor drain. Secure drain hose. This will prevent "whipping" during regenerations. **Be sure to provide a 1-1/2" minimum air gap to prevent possible sewer water backup.** See "Air Gap Requirements" section.

NOTE: In addition to a floor drain, you can use a laundry tub or standpipe as a drain point for this hose. Avoid long drain hose runs, or elevating the hose more than 8 feet above the floor.

INSTALL SALT STORAGE TANK OVERFLOW HOSE

1. Measure, cut to needed length and connect the 3/8" drain line (provided) to the salt storage tank overflow elbow and secure in place with a hose clamp.
2. Route the hose to the floor drain, or other suitable drain point no higher than the drain fitting on the salt storage tank (This is a gravity drain). If the tank overfills with water, the excess water flows to the drain point. Cut the drain line to the desired length and route it neatly out of the way.

IMPORTANT: For proper operation of the water softener, do not connect the water softener valve drain tubing to the salt storage tank overflow hose.

TEST FOR LEAKS

To prevent air pressure in the water softener and plumbing system, complete the following steps in order:

1. Fully open two or more softened cold water faucets close to the water softener, located downstream from the water softener.
2. Place the bypass valve (single or 3 valve) into the "bypass" position. See Figures 7 & 8 on Page 7.
3. Slowly open the main water supply valve. Run water until there is a steady flow from the opened faucets, with no air bubbles.
4. Place bypass valve(s) in "service" or soft water position as follows:
 - Single bypass valve: Slowly move the valve stem toward "service," pausing several times to allow the water softener to fill with water.
 - 3 valve bypass: Fully close the bypass valve and open the outlet valve. Slowly open the inlet valve, pausing several times to allow the water softener to fill with water.
5. After about three minutes, open a hot water faucet until there is a steady flow and there are no air bubbles, then close this faucet.
6. Close all cold water faucets and check for leaks at the plumbing connections that you made.
7. Check for leaks around clips at softener's inlet and outlet. If a leak occurs at a clip, depressurize the plumbing (turn off the water supply and open faucets) before removing clip. When removing clips at the softener's inlet or outlet, push the single bypass valve body toward the softener (See Figure 15). Improper removal may damage clips. Do not reinstall damaged clips.

Installation Instructions

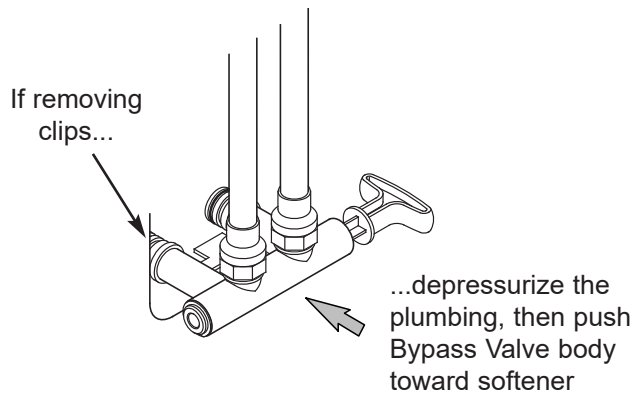

FIG. 15

ADD WATER AND SALT TO THE SALT STORAGE TANK

1. Using a container, add about three gallons of clean water into the salt storage tank.
2. Add salt to the storage tank. Use nugget, pellet or coarse solar salts with less than 1% impurities.

PLUG IN THE POWER SUPPLY

During installation, the water softener wiring may be moved or jostled from place. Be sure all leadwire connectors are secure on the back of the electronic board and be sure all wiring is away from the valve gear and motor area, which rotates during regenerations.

1. Plug the water softener's power supply into an electrical outlet that is not controlled by a switch and is approved by local codes.

NOTE: The water heater is filled with hard water and, as hot water is used, it will refill with conditioned water. In a few days, the hot water will be fully conditioned. To have fully conditioned hot water immediately, wait until the initial recharge is over. Then, drain the water heater (following instructions for water heater) until water runs cold.

PROGRAM THE CONTROLLER

1. Install the softener's top cover and salt lid.
2. Complete the Programming Steps on Pages 12-14.

SANITIZE THE WATER SOFTENER / SANITIZE AFTER SERVICE

Care is taken at the factory to keep your unit clean and sanitary. Materials used to make the unit will not infect or contaminate your water supply, and will not cause bacteria to form or grow. However, during shipping, storage, installation and operation, bacteria could get into the unit. For this reason, sanitizing as follows is suggested* when installing.

1. Slide open the salt lid, remove the brinewell cover and pour about 3 oz. (6 tablespoons) of household bleach into the softener brinewell. Replace the brinewell cover.
2. Make sure the bypass valve(s) is in the "service" (open) position.
- 3 **Start a recharge:** Press the RECHARGE button and hold for 3 seconds, until "Recharge Now" begins to flash in the display. This recharge draws the sanitizing bleach into and through the water softener. Any air remaining in the unit is purged to the drain.
4. After the recharge has completed, fully open a cold water faucet, downstream from the softener, and allow 50 gallons of water to pass through the system. This should take at least 20 minutes. Close the faucet.

*Recommended by the Water Quality Association. On some water supplies, the unit may need periodic disinfecting.

RESTART THE WATER HEATER

1. Turn on the electricity or fuel supply to the water heater and relight the pilot, if applicable.

NOTE: The water heater is filled with hard water and, as hot water is used, it refills with conditioned water. In a few days, the hot water will be fully conditioned. To have fully conditioned hot water immediately, wait until the initial recharge (previous step) is over. Then, drain the water heater (following instructions for water heater) until water runs cold.

Questions? Call Toll Free 1-800-754-7027 or visit www.rheemwatertreatment.com

When you call, please be prepared to provide the model and serial number, found on the rating decal inside the salt lid.

Programming the Water Softener

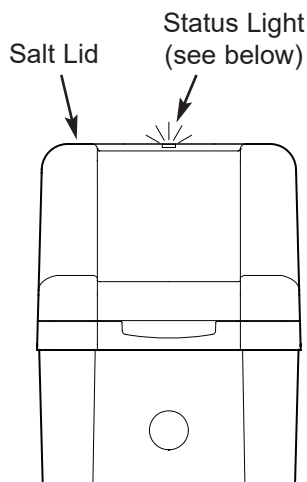

FIG. 16

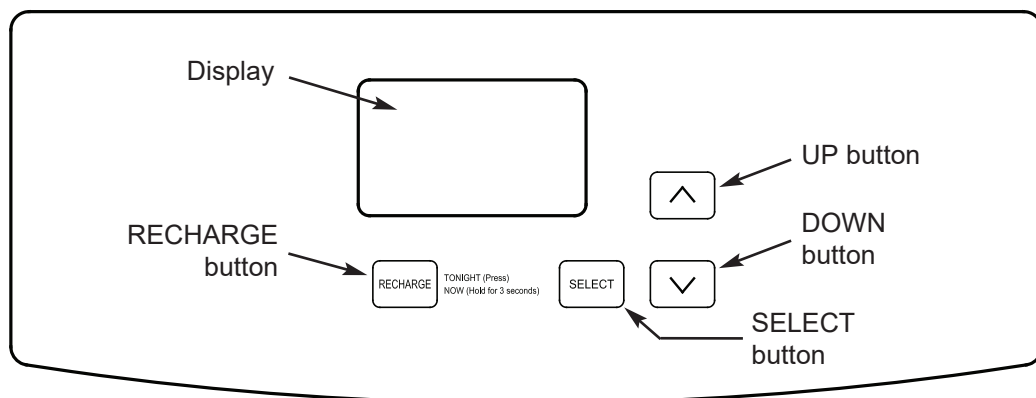

FIG. 18

STATUS LIGHT / CLEAN REMINDER

When the water softener is connected to electrical power, the status light above the control panel will operate as follows:

| Blue status light indication | Status |
|--|---|
| Flashing slowly | The salt monitor system indicates a low salt level and needs to be set. See "Set Salt Level" on Page 13. |
| Flashing slowly, with "CLEAn" in the display (Fig. 17) | Four months have elapsed on the system's timer since start up or the last reset. See below. |
| Flashing rapidly, with "SET TIME" in the display and the clock flashing slowly | The present time needs to be set, either during initial start up or after a long power outage. See "Set Present Time of Day", at right. |
| Flashing rapidly, with "Err" in the display | The electronic self-diagnostics have detected a problem. See "Troubleshooting" on Page 19. |
| On steady (not flashing) | The system has power and does not require any attention. |

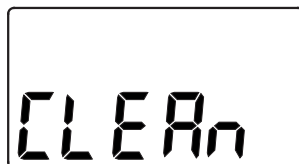

FIG. 17

This is a reminder to use **Rheem® RHWSC Water Softener Cleaner** three times a year. To reset the timer, press any button on the control panel and "CLEAn" will disappear. The status light will stop flashing, unless the system is also low on salt.

PROGRAM THE SOFTENER

When the power supply is plugged into the electrical outlet, the model code (rH32) and a software version number (example: J4.0), are briefly shown in the display. Then the words "SET TIME" appear and "12:00 PM" begins to flash.

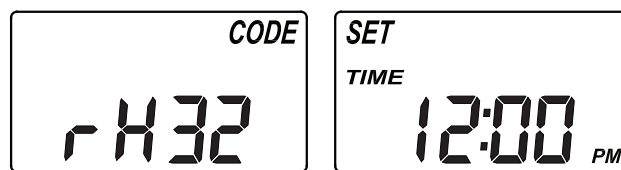

FIG. 19

STEP 1. SET PRESENT TIME OF DAY

If the words "SET TIME" do not show in the display, press the SELECT button a few times until they do.

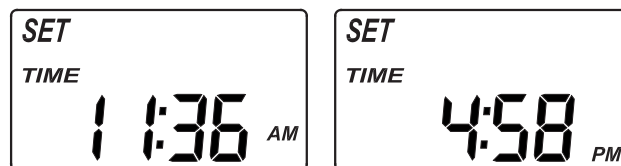

FIG. 20

1. Press the \triangle UP or ∇ DOWN buttons to set the present time. Up moves the display ahead; down sets the time back.

NOTE: Press buttons and quickly release to slowly advance the display. Hold the buttons down for fast advance.

2. When the correct time is displayed, press the SELECT button, and the display will change to show the "Hardness" screen.

continued on next page

Programming the Water Softener

STEP 2. SET WATER HARDNESS NUMBER

If you completed the previous step, the word "HARDNESS" should show in the display. Otherwise, press the SELECT button several times until it does.



FIG. 21

1. Press the \triangle UP or ∇ DOWN buttons to set the hardness of your water supply, in grains per gallon. The default is 25.

NOTE: If your water supply contains iron, compensate for it by adding to the water hardness number. For example, assume your water is 20 gpg hard and contains 2 ppm iron. Add 5 to the hardness number for each 1 ppm of iron. In this example, you would use 30 for your hardness number.

$$\begin{array}{r}
 20 \text{ gpg hardness} \\
 2 \text{ ppm iron} \times 5 = 10 \\
 \text{(times)} \quad \quad \quad +10 \\
 \hline
 30 \text{ HARDNESS NUMBER}
 \end{array}$$

2. When finished setting your water's hardness number, press the SELECT button, and the display will change to show the "Recharge Time" screen.

STEP 3. SET RECHARGE (REGENERATION) START TIME

If you completed the previous step, the words "RECHARGE TIME" should show in the display. Otherwise, press the SELECT button several times until they do.

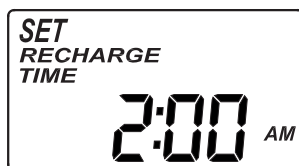

FIG. 22

1. The softener's default recharge start time is 2:00 AM. This is normally a time of day when water is not being used in the household. Hard water bypasses the softener if the household draws water during the recharge cycle. If a different recharge start time is desired, press the \triangle UP or ∇ DOWN buttons to change the time, in 1-hour increments. Be sure AM or PM is correct.
2. When the desired recharge start time is displayed, press the SELECT button, and the display will change to show one of the salt type screens in Fig. 23.

STEP 4. SET SALT TYPE

If you completed the previous step, either "NaCl" (for Sodium Chloride) or "KCl" (for Potassium Chloride) should show in the display. Otherwise, press the SELECT button several times until one of them does.

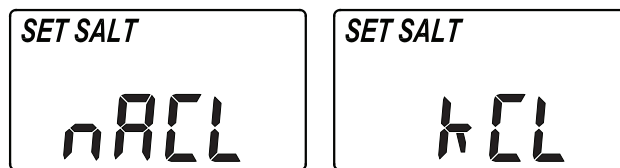

FIG. 23

1. Press the \triangle UP or ∇ DOWN buttons to set the type of salt you will be using in your water softener. The default is NaCl (standard Sodium Chloride water softener salt). If you will be using KCl (Potassium Chloride) instead, be sure to set salt type to KCl. This setting adjusts the regeneration cycle times to compensate for the different rate at which KCl dissolves. See also Page 17 for more information on salt types.
2. When the correct salt type is displayed, press the SELECT button. The display will change to show the "SET SALT LEVEL" screen.

STEP 5. SET SALT LEVEL

The water softener has a status light to remind you to refill the storage tank with salt.

NOTE: You must set salt level each time salt is added to the water softener.

To set this monitor system:

If you completed the previous step, the words "SET SALT LEVEL" should show in the display. Otherwise, press the SELECT button until they do.

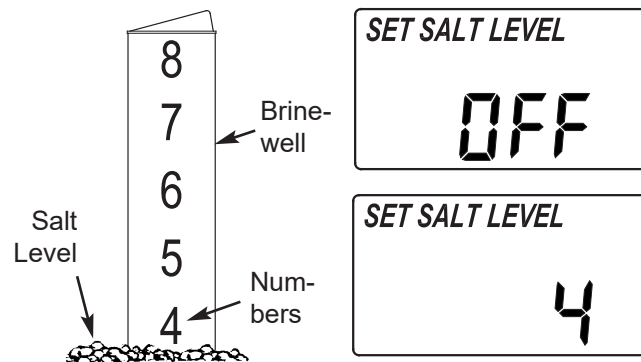

FIG. 24

1. Lift the salt lid and level the salt in the storage tank.

continued on next page

Programming the Water Softener

continued from previous page

2. The salt level scale, on the brinewell inside the tank, has numbers from 0 to 8 (See Fig. 24). Observe the highest number the leveled salt is at, or closest to.
3. Press the \triangle UP or ∇ DOWN buttons until the number on the screen corresponds to the salt level. At level 2 or below, the status light will flash. If you wish to turn this feature off, press the ∇ DOWN button past 0, and the word "OFF" flashes in the display.
4. Press the SELECT button once more to complete the initial programming. The current time of day will show in the display.

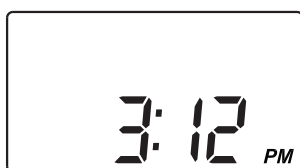

FIG. 25

PROGRAM MEMORY

If electrical power to the softener goes off, the time display is blank but the electronic controller keeps the correct time for several hours. When electrical power comes on again, you will have to reset the present time only if the display is flashing. The HARDNESS and RECHARGE TIME never require resetting unless a change is desired. Even if the clock is incorrect after a long power outage, the softener works as it should to keep your water soft, however, regenerations may occur at the wrong time of day until you reset the clock to the correct time of day.

EXTRA RECHARGE

Sometimes, a manually initiated recharge (regeneration) may be desired, or needed. Two examples are:

- You have used more water than usual (guests visiting) and you may run out of soft water before the next automatic regeneration.
- You did not add salt to the softener before it ran out. Add salt to the softener before regenerating.

You can start a regeneration immediately, or you can set the controller to regenerate at the next preset recharge time (2:00 AM, or as set).

RECHARGE NOW

Press the RECHARGE button and hold for 3 seconds, until the words "RECHARGE NOW" begin to flash in the display. The softener enters the fill cycle of regeneration immediately. This regeneration will take about 2 hours to complete. Then, you will have soft water again.

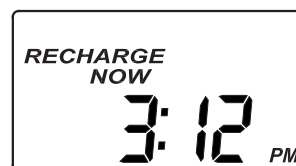

FIG. 26

RECHARGE TONIGHT

Press and release (do not hold) the RECHARGE button. "RECHARGE TONIGHT" will begin flashing in the display, and the softener will begin regeneration at the next preset recharge time (2:00 AM, or as set). If you decide to cancel the regeneration before it starts, press and release the RECHARGE button once more. "RECHARGE TONIGHT" will stop flashing in the display.

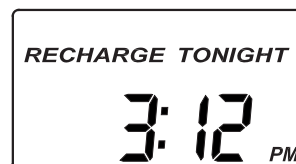

FIG. 27

Questions? Call Toll Free 1-800-754-7027 or visit www.rheemwatertreatment.com

When you call, please be prepared to provide the model and serial number, found on the rating decal inside the salt lid.

Controller Features

OPTIONAL SETTINGS:

- SALT EFFICIENCY
- MAXIMUM DAYS BETWEEN RECHARGES
- 12 / 24 HOUR CLOCK
- BACKWASH & FAST RINSE TIMES

1. To set any of these options, press and hold the SELECT button for 3 seconds until "000 - -" shows in the display.

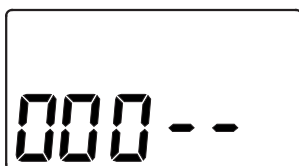

FIG. 28

Then press (do not hold) SELECT again to display one of the "Salt Efficiency" screens shown below.

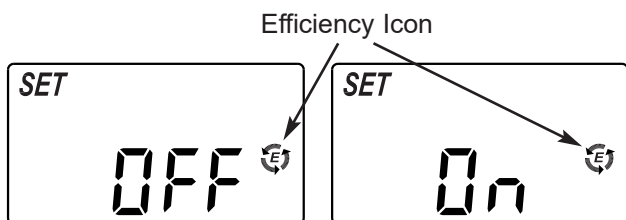

FIG. 29

SALT EFFICIENCY: When this feature is ON, the water softener will operate at salt efficiencies of 4000 grains of hardness per pound of salt or higher. The softener may recharge more often using smaller salt dosage and less water. This softener is shipped with the efficiency feature set OFF.

Use the Δ UP or ∇ DOWN buttons to change between OFF and ON. An efficiency icon will be displayed when this feature is ON.

California Efficiency Requirement

Your Rheem® Water Softener has a "High Efficiency" feature that can be set ON or OFF. This softener is shipped with the efficiency feature set OFF, which will utilize the maximum rated capacity while most often achieving maximum salt efficiencies. When installing this unit in the State of California, you MUST turn the efficiency feature ON. The softener may initiate more frequent recharges, but it will operate at 4000 grains per pound of salt or higher.

Displayed when efficiency is set to "ON"

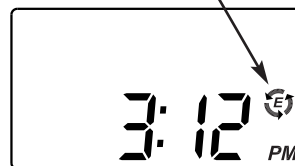

FIG. 30

2. Press SELECT again to display the "Set Recharge Days" screen.

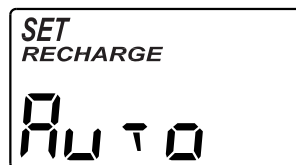

FIG. 31

MAXIMUM DAYS BETWEEN REGENERATIONS:

The electronic controller automatically determines recharge frequency. This provides the greatest operating efficiency and, under most conditions this feature will be left in its default mode. However, you can set this feature to force a recharge every set number of days. You may want to do this if, for example, your water supply contains iron and you want the softener to recharge at least once every few days to keep the resin bed clean. Use the Δ UP or ∇ DOWN buttons to change the number of days (up to 15).

3. Press SELECT again to display the "12 or 24 hr" screen.

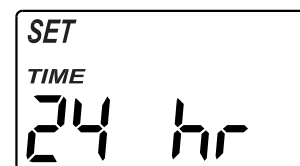
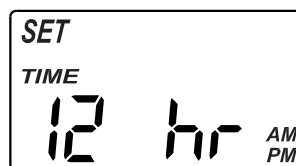

FIG. 32

12 OR 24 HOUR CLOCK: All time displays are shown in standard clock time (1 to 12 AM; and 1 to 12 PM) at the 12 hr default setting. If 24 hour time format is desired, set to 24 hr by pressing the Δ UP button.

4. Press SELECT again to display the backwash time "Add" screen.

continued on next page

Controller Features

continued from previous page

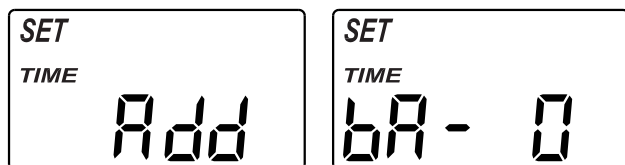

FIG. 33

BACKWASH & FAST RINSE TIMES: If you experience salty tasting water after recharge, you may need to increase the backwash and fast rinse times. The cycle times during recharge are determined by the softener's electronic controller. However, you may increase the backwash and fast rinse times, in 1 minute increments.

If you wish to increase the backwash time, use the \triangle UP or ∇ DOWN buttons to add up to 15 minutes. Then press the OK button to display the fast rinse time "Add" screen.

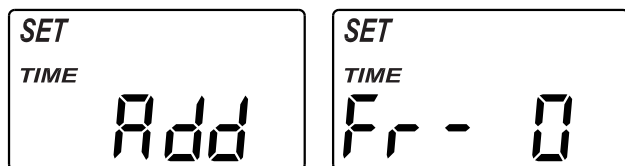

FIG. 34

If you wish to increase the fast rinse time, use the \triangle UP or ∇ DOWN buttons to add up to 15 minutes.*

5. Press SELECT to return to the normal run (time of day) screen.



FIG. 35

* Setting backwash and/or fast rinse times too low may result in salty tasting water after regeneration.

Routine Maintenance

ADDING SALT

Lift the salt lid and check the salt storage level frequently. If the water softener uses all the salts before you refill it, you will experience hard water. Until you have established a refilling routine, check the salt every two or three weeks. Always add if less than 1/4 full. Be sure the brinewell cover is on.

NOTE: In humid areas, it is best to keep the salt storage level lower, and to refill more often to avoid salt “bridging”.

Recommended Salt: Nugget, pellet or coarse solar salts with less than 1% impurities.

Salt Not Recommended: Rock salt, high in impurities, block, granulated, table, ice melting, ice cream making salts, etc.

BREAKING A SALT BRIDGE

Sometimes, a hard crust or salt “bridge” forms in the brine tank. It is usually caused by high humidity or the wrong kind of salt. When the salt “bridges,” an empty space forms between the water and the salt. Then, salt will not dissolve in the water to make brine. Without brine, the resin bed is not recharged and hard water will result.

If the storage tank is full of salt, it is difficult to tell if you have a salt bridge. A bridge may be underneath loose salt. Take a broom handle, or like tool, and hold it next to the water softener. Measure the distance from the floor to the rim of the water softener. Then, carefully push the broom handle straight down into the salt. If a hard object is felt before the pencil mark is even with the top, it is most likely a salt bridge. Carefully push into the bridge in several places to break it. Do not use any sharp or pointed objects as you may puncture the brine tank. Do not try to break the salt bridge by pounding on the outside of the salt tank. You may damage the tank.

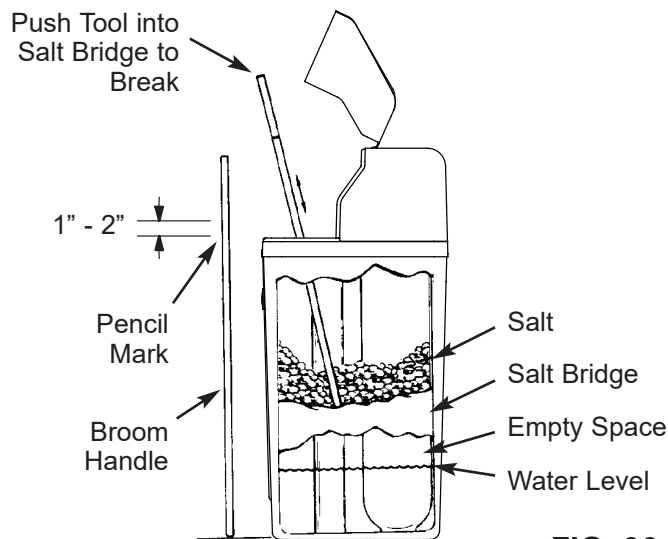

FIG. 36

Questions? Call Toll Free 1-800-754-7027 or visit www.rheemwatertreatment.com

When you call, please be prepared to provide the model and serial number, found on the rating decal inside the salt lid.

Routine Maintenance

CLEANING THE NOZZLE & VENTURI

A clean nozzle & venturi (See Figure 37) is a necessity for the water softener to work properly. This small component creates the suction to move brine from the brine tank, into the resin tank. If it should become plugged with sand, silt, dirt, etc., the water softener will not work, and hard water will result.

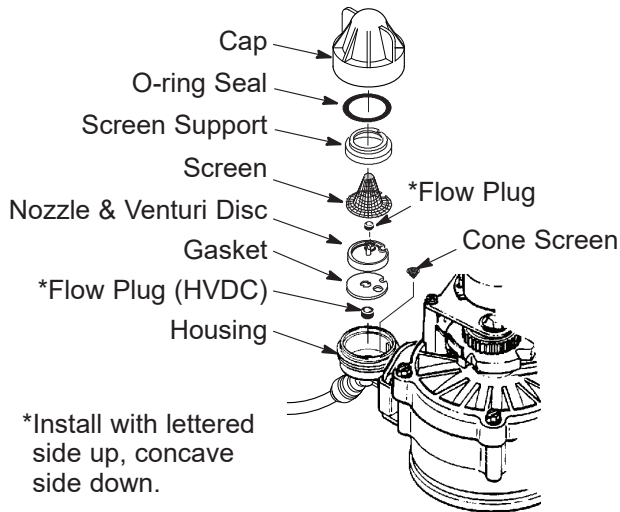

IMPORTANT: Be sure small hole in the gasket is centered directly over the small hole in the nozzle & venturi housing. Be sure the numbers are facing up

FIG. 37

To get access to the nozzle & venturi, remove the water softener's top cover. Put the bypass valve(s) into the bypass position. Be sure the water softener is in soft water (service) cycle (no water pressure at nozzle & venturi). Then, holding the nozzle & venturi housing with one hand, unscrew the cap. Do not lose the o-ring seal. Lift out the screen support and screen. Then, remove the nozzle & venturi disc, gasket and flow plug(s). Wash the parts in warm, soapy water and rinse in fresh water. Be sure to clean both the top and bottom of the nozzle & venturi disc. If needed, use a small brush to remove iron or dirt. Do not scratch, misshape, etc., surfaces of the nozzle & venturi.

Gently replace all parts in the correct order. Lubricate the o-ring seal with silicone grease and locate in place. Install and tighten the cap by hand, while supporting the housing. Overtightening may break the cap or housing. Put the bypass valve(s) into service (soft water) position.

Recharge the softener to reduce water level in the tank. This will also assure that the softener is completely recharged and ready to provide softened water again. Check the water level in the tank by looking down the brinewell. If the water level does not drop after a recharge, the problem has not been resolved. Call 1-800-754-7027.

PROTECT THE WATER SOFTENER FROM FREEZING

If the softener is installed where it could freeze (summer cabin, lake home, etc.), you must drain all water from it to stop possible freeze damage. To drain the softener:

1. Close the shut-off valve on the house main water pipe, near the water meter or pressure tank.
2. Open a faucet in the soft water pipes to vent pressure in the softener.
3. Move the stem in the single bypass valve to bypass. Close the inlet and outlet valve in a 3 valve bypass system, and open the bypass valve. If you want water in the house pipes again, reopen the shut-off valve on the main water pipe.
4. Unplug the power supply at the wall outlet. Remove the softener's top cover, together with the salt lid. Take off both drain hoses if they will interfere with moving the softener into position over the drain.
5. Carefully remove the large holding clips at the softener inlet and outlet. Separate the softener from the plastic installation adaptors, or from the bypass valve.
6. Lay a piece of 2 inch thick board near the floor drain (See Figure 38).
7. Move the softener close to the drain. Slowly and gently, tip it over until the rim rests on the wood block with the inlet and outlet over the drain. Do not allow the softener's weight to rest on the inlet and outlet fittings or they may break.
8. Tip the bottom of the softener up a few inches and hold until all water has drained. Leave the softener laying like this until you are ready to use it. Plug the inlet and outlet with clean rags to keep dirt, bugs, etc. out.

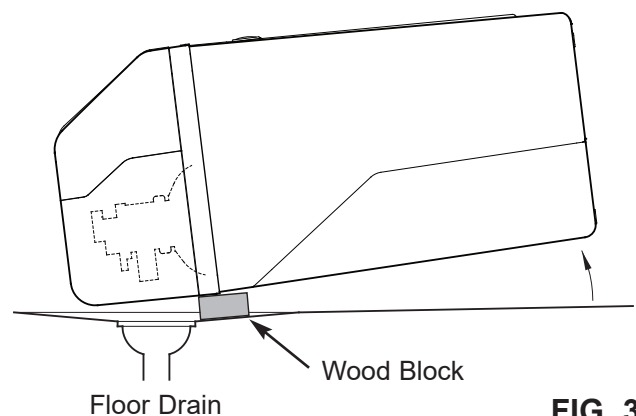

FIG. 38

Troubleshooting Guide

| PROBLEM | CAUSE | CORRECTION |
|--|--|---|
| No soft water | 1. No salt in the storage tank. | Refill with salt and then use RECHARGE NOW feature. |
| No soft water & display is blank | 1. Power supply unplugged at wall outlet, or power cable disconnected from back of electronic board or power supply malfunction. | Check for loss of power and correct. Reset electronic controls and then use RECHARGE NOW feature. |
| | 2. Fuse blown, circuit breaker popped, or circuit switched off (See "Program Memory" on Page 14). | Replace fuse, reset circuit breaker, or switch circuit on, and then use RECHARGE NOW feature. |
| | 3. Electronic control board malfunction. | Replace electronic control board (See Page 23). |
| No soft water & salt level not dropping | 1. Salt storage tank "bridged". | Refer to "Breaking a Salt Bridge" section to break. |
| | 2. Bypass valve(s) in "bypass" position. | Move bypass valve(s) to "service" position. |
| No soft water & salt storage tank full of water, water running to drain while unit is in the soft water cycle | 1. Dirty, plugged or damaged nozzle & venturi assembly | Take apart, clean and inspect nozzle & venturi (See "Cleaning the Nozzle & Venturi" section). |
| | 2. Inner valve fault causing leak. | Replace seals and rotor. |
| | 3. Valve drain hose is plugged. | Hose must not have any kinks, sharp bends or any water flow blockage (See "Valve Drain Requirements" section). |
| | 4. Valve drain line and Salt Storage Tank overflow drain connected together by a tee. | Disconnect tee and run separate drain lines. |
| | 5. Low or high system water pressure (low pressure may disrupt brine draw during recharge, high pressure may cause inner valve parts failure). | If pressure is low, increase well pump output to a minimum 20 psi. If daytime pressure is over 100 psi, add a pressure reducing valve in the supply pipe to the softener. Contact a licensed plumber. |
| | 6. Brine float dirty or broken. | Clean or replace Brine Valve Float Assembly. |
| | 7. Leak between valve and resin tank. | Replace o-rings between resin tank and valve. |
| Water hard sometimes | 1. Incorrect time set. | Check and change time setting. |
| | 2. Incorrect water hardness set. | Refer to "Set Water Hardness" section to set correctly. |
| | 3. Incorrect model code programmed. | Refer to "Program the Water Softener" section to set correctly. |
| | 4. Hot water being used when softener is regenerating. | Avoid using hot water while the softener is regenerating, as the water heater will fill with hard water. |
| | 5. Possible increase in water hardness. | Test untreated water for hardness and iron, and program the water softener accordingly (See "Set Water Hardness") section to set. |
| | 6. Leaking faucet or toilet valve. Excessive water usage. | A small leak can waste hundreds of gallons of water in a few days. Fix all leaks and always fully close faucets. |
| Iron in water | 1. Clear water iron in water supply. | Test untreated water for hardness and iron, and program the water softener accordingly (See "Set Water Hardness") section to set. |
| | 2. Iron in soft water. | Clean resin bed with Resin Bed Cleaner. Follow instructions on package. |
| | 3. Bacterial or organic bound iron. | Cannot be treated by water softener. |
| Resin in household plumbing | 1. Crack in distributor or riser tube. | Replace resin tank assembly. |
| Salt storage tank leaking | 1. Crack in brine tank. | Replace salt storage tank assembly. |
| Motor stalled or clicking | 1. Motor malfunction or internal valve fault causing high torque on motor. | a. Replace rotor/seal. b. Replace motor & switch. |
| Error code E1, E3 or E4 appears | 1. Fault in wiring harness or connections to position switch. | Replace wiring harness or connections to position switch. |
| | 2. Fault in switch. | Replace switch. |
| | 3. Fault in valve causing high torque. | Replace rotor/seal. |
| | 4. Motor inoperative. | Replace motor. |
| Error code E5 | 1. Electronic control malfunction. | Replace electronic control board. |
| Status light off, but display is not blank | 1. Status light dislodged from its holder. | Remove top cover and reinsert status light into its holder. |

Troubleshooting

AUTOMATIC ELECTRONIC DIAGNOSTICS

This water softener has a self-diagnostic function for the electrical system (except input power and/or water meter). The water softener monitors electronic components and circuits for correct operation. If a malfunction occurs, an error code appears in the display.

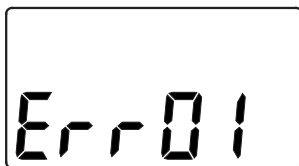

FIG. 39

While an error code appears in the display, all buttons are inoperable except the SELECT button. SELECT remains operational so the service person can perform the Manual Advance Diagnostics, see below, to further isolate the problem.

Procedure for removing error code from display:

1. Unplug transformer from electrical outlet.
2. Correct problem.
3. Plug in transformer.
4. Wait 8 minutes. The error code will return if the problem was not corrected.

MANUAL ADVANCE DIAGNOSTICS

Use the following procedures to advance the water softener through the regeneration cycles to check operation.

Lift off the salt lid, remove the top cover by unlocking the tabs in the back and rocking forward, to observe cam and switch operation during valve rotation.

1. Press and hold SELECT for 3 seconds until "000" shows in the display, then release.
2. The 3 digits indicate water meter operation as follows:
 - 000 (steady) = Soft water not in use, and no flow through the meter.Open a nearby soft water faucet.
 - 000 to 199 (continual) = Repeats for each gallon of water passing through the meter.

3. The letter "P" and a dash (or dashes) indicate POSITION switch operation (See Figure 40). If the letter appears, the switch is closed. If the dash shows, the switch is open.

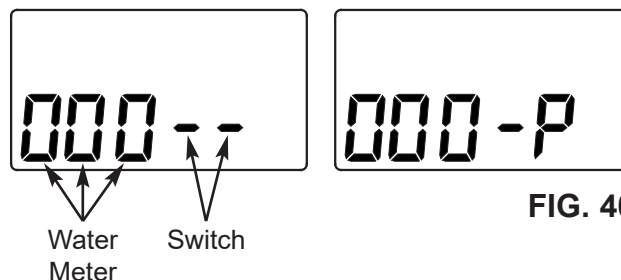

FIG. 40

4. Use the RECHARGE button to manually advance the valve into each cycle and check correct switch operation.

NOTE: Be sure water is in contact with the salt, and not separated by a salt bridge (See "Breaking A Salt Bridge" section).

5. While in this diagnostic screen, the following information is available and may be beneficial for various reasons. This information is retained by the computer from the first time electrical power is applied to the electronic controller.
 - a. Press the Δ UP button to display the number of days this electronic control has had electrical power applied.
 - b. Press the ∇ DOWN button to display the number of regenerations initiated by this electronic control since the code number was entered.
6. Press and hold the SELECT button until the model code (rH32) shows in the display. This code identifies the softener model. If an incorrect model code is displayed, the softener will operate on incorrect configuration data.



FIG. 41

7. To change the code number, press the Δ UP or ∇ DOWN button until the correct code shows.
8. To return to the present time display, press the SELECT button.

Need help troubleshooting? Call Toll Free 1-800-754-7027 or visit www.rheemwatertreatment.com

When you call, please be prepared to provide the model and serial number, found on the rating decal inside the salt lid.

Troubleshooting

RESETTING TO FACTORY DEFAULTS

To reset the electronic controller to its factory default for all settings (time, hardness, etc.):

1. Press the SELECT button and hold it until the display changes twice to show the flashing model code.
2. Press the \triangle UP button (a few times, if necessary) to display a flashing "SoS".

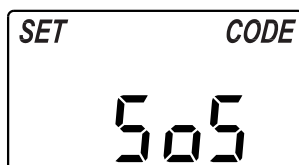

FIG. 42

3. Press the SELECT button, and the electronic controller will restart.
4. Set the present time, hardness, etc., as described on pages 12-14.

MANUAL ADVANCE RECHARGE CHECK

This check verifies proper operation of the valve motor, brine tank fill, brine draw, recharge flow rates, and other controller functions. Always make the initial checks, and the manual initiated diagnostics.

NOTE: The electronic control display must show a steady time (not flashing). If an error code shows, first press the SELECT button to enter the diagnostic display.

1. Press the RECHARGE button and hold in for 3 seconds. RECHARGE begins to flash as the softener's valve advances from the service to fill position. Remove the brinewell cover and, using a flashlight, observe fill water entering the tank.

If water does not enter the tank, look for an obstructed nozzle, venturi, fill flow plug, brine tubing, or brine valve riser pipe.

2. After observing fill, press the RECHARGE button to move the softener's valve into the brine position. A

slow flow of water to the drain will begin. Verify brine draw from the brine tank by shining a flashlight into the brinewell and observing a noticeable drop in the liquid level. This may take 15 to 20 minutes.

NOTE: Be sure water is in contact with the salt, and not separated by a salt bridge (See "Breaking A Salt Bridge" section).

If the water softener does not draw brine, check for (most likely to least likely):

- Dirty or plugged nozzle and venturi, see "Cleaning the Nozzle and Venturi" section.
- Nozzle and venturi not seated on the gasket, or gasket deformed.
- Valve seals leaking (See Troubleshooting).
- Restriction in valve drain, causing a back-pressure (bends, kinks, elevated too high, etc.). See "Install Valve Drain Hose" section.
- Obstruction in brine valve or brine tubing.

NOTE: If water system pressure is low, a too-long or elevated drain hose may cause back pressure, stopping brine draw. Avoid drain hose runs longer than 30 feet. Avoid elevating the hose more than 8 feet above the floor.

3. Press the RECHARGE button to move the softener's valve into the backwash position. Look for a fast flow of water from the drain hose. Check that the drain can adequately handle the flow and volume.

An obstructed flow indicates a plugged top distributor, backwash flow plug, or drain hose.

4. Press the RECHARGE button to move the softener's valve into the fast rinse position. Again look for a fast drain flow. Allow the softener to rinse for a few minutes to flush out any brine that may remain in the resin tank from the brining cycle test.
5. To return the softener's valve to the service position, press the RECHARGE button.

WIRING SCHEMATIC

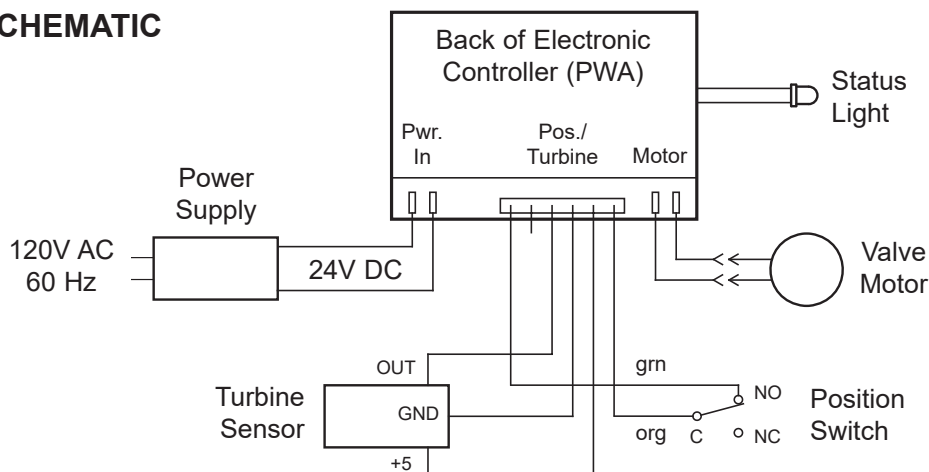
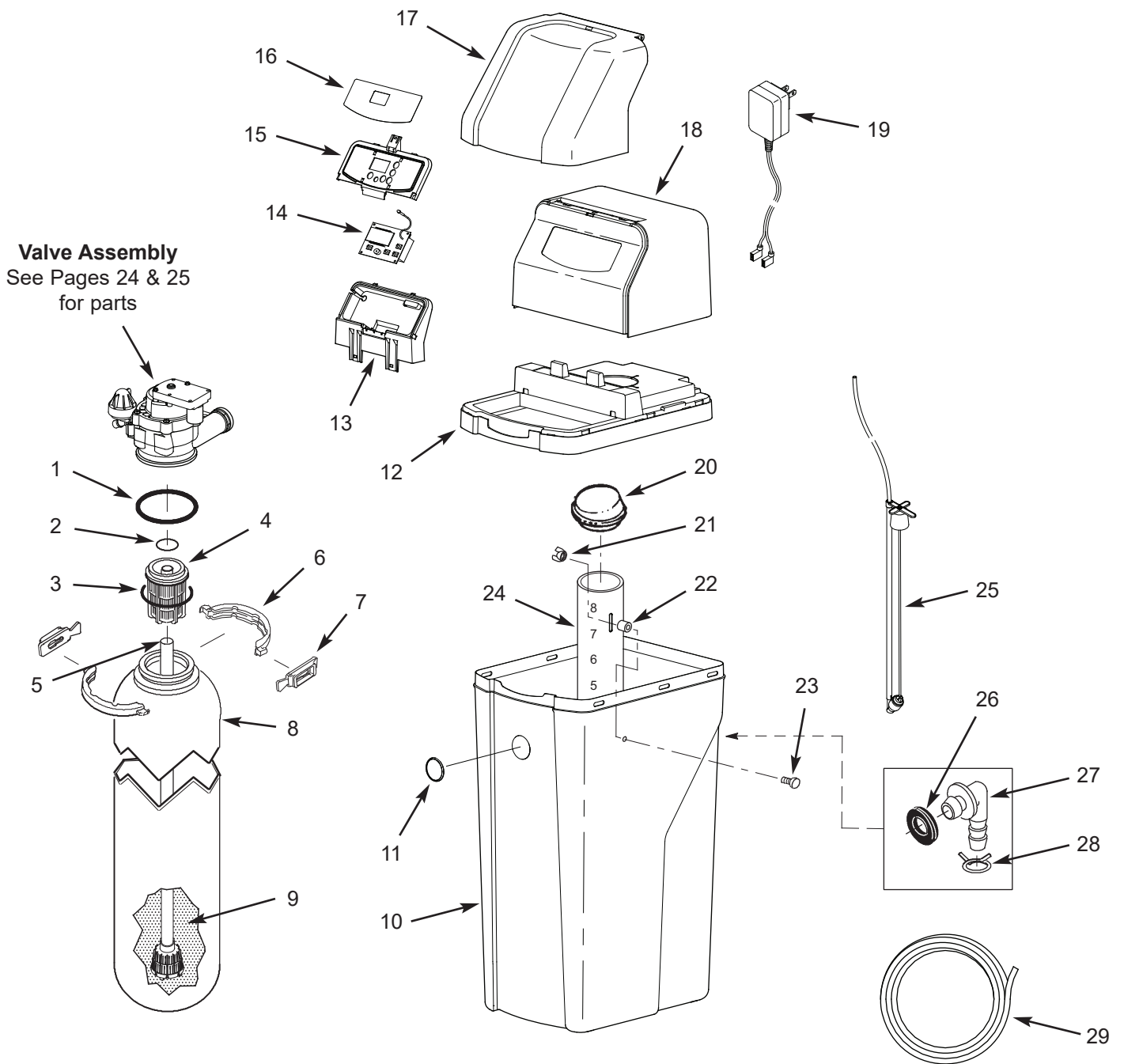

FIG. 43

Softener Exploded View



Softener Parts List

| Key No. | Part No. | Description |
|---------|----------|---|
| – | 7112963 | Distributor O-Ring Kit (includes Key Nos. 1-3) |
| 1 | ↑ | O-Ring, 2-7/8" x 3-1/4" |
| 2 | ↑ | O-Ring, 13/16" x 1-1/16" |
| 3 | ↑ | O-Ring, 2-3/4" x 3" |
| 4 | 7077870 | Top Distributor |
| 5 | 7329219 | Repl. Bottom Distributor |
| – | 7331177 | Tank Neck Clamp Kit (includes 2 ea. of Key Nos. 6 & 7) |
| 6 | ↑ | Clamp Section (2 req.) |
| 7 | ↑ | Retainer Clip (2 req.) |
| 8 | 7328904 | Repl. Resin Tank, 9" x 35" |
| 9 | 0502272 | Resin, 1 cu. ft. |
| 10 | 7384667 | Repl. Brine Tank (includes badge below) |
| 11 | 7386538 | Badge, Rheem |
| 12 | 7384641 | Rim |
| 13 | 7384633 | Support, Faceplate |
| 14 | 7386766 | Repl. Electronic Control Board (PWA), including status light |

| Key No. | Part No. | Description |
|---------|----------|--|
| 15 | 7384625 | Faceplate (order decal below) |
| 16 | 7385540 | Faceplate Decal |
| 17 | 7386839 | Salt Lid (order decal below) |
| ■ | 7386716 | Instruction Decal |
| 18 | 7386821 | Top Cover |
| 19 | 7351054 | Power Supply, 24V DC |
| 20 | 7386855 | Cover, Brinewell |
| – | 7386978 | Brinewell Mounting Hardware Kit (includes Key Nos. 21-23) |
| 21 | ↑ | Wing Nut, 1/4-20 |
| 22 | ↑ | Spacer, 3/4" long |
| 23 | ↑ | Screw, 1/4-20 x 1-1/2" |
| 24 | 7214375 | Brinewell |
| 25 | 7381180 | Brine Valve Assembly |
| – | 7331258 | Overflow Hose Adaptor Kit (includes Key Nos. 26-28) |
| 26 | ↑ | Grommet |
| 27 | ↑ | Adaptor Elbow |
| 28 | ↑ | Hose Clamp |
| 29 | 7139999 | Drain Hose |

■ Not illustrated.

To order repair parts, call toll free 1-800-754-7027.

Manufactured and warranted by
Water Channel Partners
2805 Dodd Road, Suite 300
Eagan, MN 55121

Questions? Call Toll Free 1-800-754-7027 or visit www.rheemwatertreatment.com

When you call, please be prepared to provide the model and serial number,
found on the rating decal inside the salt lid.

Valve Exploded View

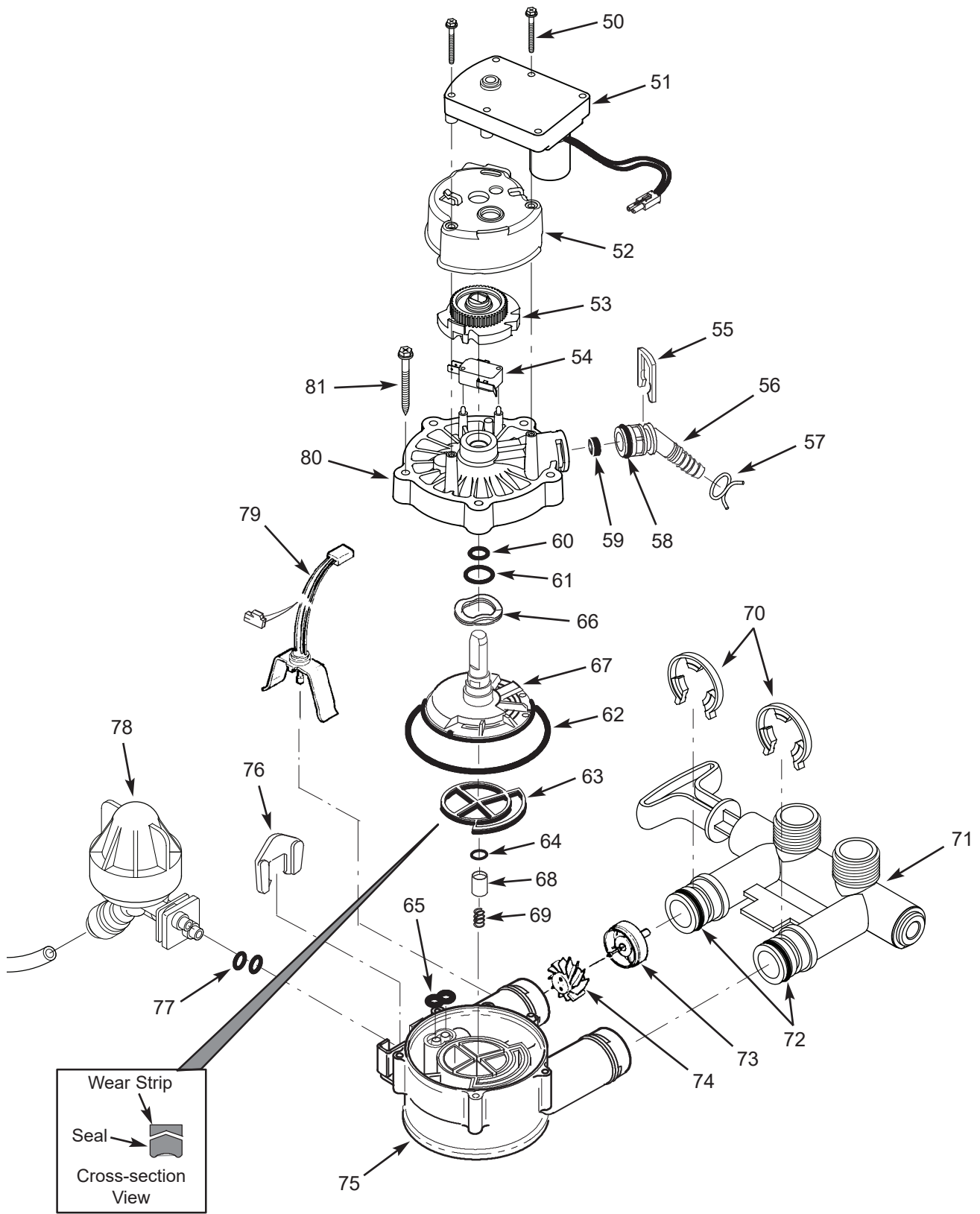

Valve Parts List

| Key No. | Part No. | Description |
|---------|----------|--|
| - | 7397864 | Motor, Cam & Gear Kit, 3/4" (includes Key Nos. 50-53) |
| 50 | ↑ | Screw, #6-19 x 1-3/8" (2 pcs.) |
| 51 | ↑ | Motor |
| 52 | ↑ | Motor Mount |
| 53 | ↑ | Cam & Gear |
| 54 | 7030713 | Switch |
| - | 7331185 | Drain Hose Adaptor Kit (includes Key Nos. 55-59) |
| 55 | ↑ | Clip, Drain |
| 56 | ↑ | Drain Hose Adaptor |
| 57 | ↑ | Hose Clamp |
| 58 | ↑ | O-Ring, 5/8" x 13/16" |
| 59 | ↑ | Flow Plug, 2.0 gpm |
| - | 7129716 | Seal Kit (includes Key Nos. 60-65) |
| 60 | ↑ | O-Ring, 7/16" x 5/8" |
| 61 | ↑ | O-Ring, 3/4" x 15/16" |
| 62 | ↑ | O-Ring, 3-3/8" x 3-5/8" |
| 63 | ↑ | Rotor Seal |
| 64 | ↑ | O-Ring, 3/8" x 9/16" |
| 65 | ↑ | Seal, Nozzle & Venturi |
| 66 | 7082087 | Wave Washer |
| 67 | 7199232 | Rotor & Disc |

| Key No. | Part No. | Description |
|---------|----------|--|
| - | 7342665 | Drain Plug Kit, 3/4" (includes Key Nos. 64, 68 & 69) |
| 68 | ↑ | Plug, Drain Seal |
| 69 | ↑ | Spring |
| 70 | 7337563 | Clip, 3/4", pack of 4 |
| 71 | 7370286 | Bypass Valve Assembly, 3/4", in- cluding 2 O-Rings (See Key No. 72) |
| 72 | 7337571 | O-Ring, 15/16" x 1-3/16", pack of 4 |
| - | 7113040 | Turbine & Support Assembly, including 2 O-Rings (See Key No. 72) & 1 ea. of Key Nos. 73 & 74 |
| 73 | ↑ | Turbine Support & Shaft |
| 74 | ↑ | Turbine |
| 75 | 7082053 | Valve Body |
| - | 7398674 | Nozzle & Venturi Kit (includes Key Nos. 76-78) |
| 76 | ↑ | Retainer, Nozzle & Venturi |
| 77 | ↑ | O-Ring, 1/4" x 3/8" (2 pcs.) |
| 78 | ↑ | Nozzle & Venturi Assembly |
| 79 | 7309803 | Wire Harness, Sensor |
| 80 | 7337466 | Valve Cover |
| 81 | 7342657 | Screw, #10-14 x 2", pack of 5 |

To order repair parts, call toll free 1-800-754-7027.

Manufactured and warranted by
Water Channel Partners
2805 Dodd Road, Suite 300
Eagan, MN 55121

Questions? Call Toll Free 1-800-754-7027 or visit www.rheemwatertreatment.com

When you call, please be prepared to provide the model and serial number,
found on the rating decal inside the salt lid.

EXTEND YOUR WARRANTY:

Use Rheem® RHWSC Water Softener Cleaner

The factory warranty for your water softener is shown below. The one year full warranty period on parts and labor can be extended to five (5) years from the date the product is delivered if you use Rheem® RHWSC Water Softener Cleaner on your system. Use one bottle of Rheem® RHWSC Water Softener Cleaner, as directed, every four months from the date the water softener is delivered. Retain proof of purchase of Rheem® RHWSC Water Softener Cleaner to validate any warranty claim after the first year. Purchase of no more than three (3) bottles of Rheem® RHWSC Water Softener Cleaner in a 12 month period may be applied toward compliance with this warranty. Use of any water softener additive other than Rheem® RHWSC will not provide extended warranty coverage.

WATER SOFTENER WARRANTY - MODEL RHS32

Warrantor: Water Channel Partners, 2805 Dodd Road, Suite 300, Eagan, MN 55121

Warrantor guarantees to the original purchaser when the product is purchased from an authorized dealer, and when installed and maintained in accordance with the instructions, that:

One Year Full Warranty:

- For a period of one (1) year from the date the product is delivered, all parts will be free from defects in materials and workmanship and will perform in accordance with their written specifications.
- For a period of one (1) year from the date the product is delivered, labor to repair or replace any part determined by Warrantor to be defective in materials or workmanship, will be provided at no additional cost.

Limited Warranties:

- For a period of ten (10) years from the date the product is delivered, the salt storage tank and fiberglass resin/mineral tank will not rust, corrode, leak, burst, or in any other manner, fail to perform in accordance with their written specifications.
- For a period of three (3) years from the date the product is delivered, the electronic control board will be free of defects in materials and workmanship and will perform in accordance with its written specifications.

If, during such respective period, a part proves to be defective, Warrantor will ship a replacement part, directly to your home, without charge. If a repair or replacement part is unavailable, Warrantor may refund the original purchase price. After the first year, labor necessary to maintain this product is not covered by the product warranty.

If you have questions regarding a warranted product, need assistance with installation or troubleshooting, wish to order a part or report a warranty issue, we are just a phone call away. SIMPLY DIAL 1-800-754-7027 for assistance.

General Provisions

The above warranties are effective provided the water softener is operated at water pressures not exceeding 125 psi (8.8 kg/cm²), and at water temperatures not exceeding 120°F (49°C); provided further that the water softener is not subject to abuse, misuse, alteration, neglect, freezing, accident or negligence; and provided further that the water softener is not damaged as the result of any force of nature such as, but not limited to, flood, hurricane, tornado or earthquake.

The limited warranty does not cover damage due to: (a) transportation, (b) storage, (c) improper use, (d) failure to follow the product instructions or to perform any preventive maintenance, (e) modifications, (f) unauthorized repair, (g) normal wear and tear, or (h) external causes such as accidents, abuse, or other actions or events beyond Warrantor's reasonable control. Use of aftermarket, used, or non-manufacturer provided parts will void all warranties. Warranty does not cover failures due to improper product installation. Warrantor is excused if failure to perform its warranty obligations is the result of strikes, government regulation, materials shortages, or other circumstances beyond its control.

THERE ARE NO WARRANTIES ON THE WATER SOFTENER BEYOND THOSE SPECIFICALLY DESCRIBED ABOVE. ALL IMPLIED WARRANTIES, INCLUDING ANY IMPLIED WARRANTY OF MERCHANTABILITY OR OF FITNESS FOR A PARTICULAR PURPOSE, ARE DISCLAIMED TO THE EXTENT THEY MIGHT EXTEND BEYOND THE ABOVE PERIODS. THE SOLE OBLIGATION OF WARRANTOR UNDER THESE WARRANTIES IS TO REPLACE OR REPAIR THE COMPONENT OR PART WHICH PROVES TO BE DEFECTIVE WITHIN THE SPECIFIED TIME PERIOD, AND WARRANTOR IS NOT LIABLE FOR CONSEQUENTIAL OR INCIDENTAL DAMAGES. NO DEALER, AGENT, REPRESENTATIVE, OR OTHER PERSON IS AUTHORIZED TO EXTEND OR EXPAND THE WARRANTIES EXPRESSLY DESCRIBED ABOVE.

Some states do not allow the exclusion or limitation of incidental or consequential damages, so the above limitation or exclusion may not apply to you. This warranty gives you specific legal rights, and you may have other rights which vary from state to state. This warranty applies to consumer-owned installations only.

THIS PRODUCT IS MANUFACTURED BY WATER CHANNEL PARTNERS. THE ONLY WARRANTIES FOR THIS WATER SOFTENER ARE THOSE SPECIFICALLY DESCRIBED IN THE ABOVE WARRANTY, WHICH IS PROVIDED BY WATER CHANNEL PARTNERS. RHEEM MAKES NO EXPRESS OR IMPLIED WARRANTIES OF ANY KIND WITH RESPECT TO THIS WATER SOFTENER. ALL IMPLIED WARRANTIES ON THE WATER SOFTENER INCLUDING, WITHOUT LIMITATION, WARRANTIES THAT THE WATER SOFTENER IS FREE OF DEFECTS, MERCHANTABILITY, FIT FOR A PARTICULAR PURPOSE, OR NON-INFRINGEMENT ARE EXPRESSLY DISCLAIMED. RHEEM SHALL NOT BE LIABLE, DIRECTLY OR INDIRECTLY, FOR ANY LOSS, COST, DAMAGE OR EXPENSE, INCLUDING, WITHOUT LIMITATION, CONSEQUENTIAL OR INCIDENTAL DAMAGES, ARISING DIRECTLY OR INDIRECTLY FROM THE OPERATION, CONDITION OR USE OF THE WATER SOFTENER.

Rheem®, Rheem Preferred, Rheem Preferred Plus, and Rheem Preferred Platinum logos and product names are trademarks of Rheem Manufacturing Company, and are used under license. All rights reserved.